



Hex-Par12

LED PAR with 6-in-1
RGBAW+UV LEDs
projects perfectly mixed
and finely tunable colors

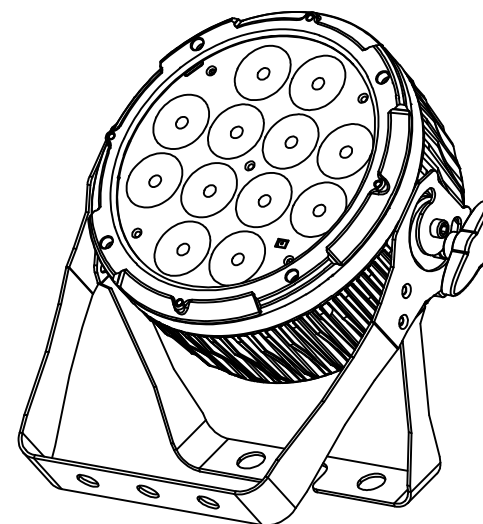

TABLE OF CONTENTS

SAFETY / GENERAL INSTRUCTIONS

INTRODUCTION

- Features
- Specifications

OVERVIEW

- Rear view

DIMENSIONS

CONTROL MENU OVERVIEW

- Control Panel
- Function Menu

UFI OPERATION

DMX FUNCTION CHART

- 11-channel mode
- 6-channel mode

STAND-ALONE OPERATION

INFRARED (IR6) REMOTE CONTROL OPERATION

MASTER/SLAVE OPERATION (via DMX cable)

MASTER/SLAVE OPERATION (via UFI wi-fi)

OPERATING MODE PRIORITY RANK

MAINTENANCE

PACKING CONTENT

- HEX-PAR 12
- Power cord
- User Manual
- Warranty Card



MAINTENANCE

MAINTENANCE AND CLEANING THE UNIT

- Make sure the area below the installation place is free from unwanted persons during setup.
- Switch off the unit, unplug the main cable and wait until the unit has cooled down.
- All screws used for installing the device and any of its parts should be tightly fastened and should not be corroded.
- Housings, fixations and installation spots (ceiling, trusses, suspensions) should be totally free from any deformation.
- The main cables must be in impeccable condition and should be replaced immediately even when a small problem is detected.
- It is recommended to clean the front at regular intervals, from impurities caused by dust, smoke, or other particles to ensure that the light is radiated at maximum brightness. For cleaning, disconnect the main plug from the socket. Use a soft, clean cloth moistened with a mild detergent. Then carefully wipe the part dry. For cleaning other housing parts use only a soft, clean cloth. Never use a liquid, it might penetrate the unit and cause damage to it.

FUSE REPLACEMENT

1. Remove the safety cap by a screwdriver.
2. Replace the blown fuse with a fuse of the exact same type and rating (T2A-250V).
3. Install the safety cap, and reconnect power.



Fig.7

TROUBLESHOOTING

Problems	Possible causes	Checks and remedies
Fixture does not light up	<ul style="list-style-type: none"> • No mains supply • Dimmer fader set to 0 • All color faders set to 0 • Faulty LED • Faulty LED board 	<ul style="list-style-type: none"> • Check the power supply voltage • Increase the value of the dimmer channels • Increase the value of the color channels • Replace the LED board • Replace the LED board
General low light intensity	<ul style="list-style-type: none"> • Dirty lens assembly • Misaligned lens assembly 	<ul style="list-style-type: none"> • Clean the fixture regularly • Install lens assembly properly
Fixture does not power up	<ul style="list-style-type: none"> • No power • Loose or damaged power cord • Faulty internal power supply 	<ul style="list-style-type: none"> • Check for power on power outlet • Check power cord • Replace internal power supply
Fixture does not respond to DMX	<ul style="list-style-type: none"> • Wrong DMX addressing • Damaged DMX cables • Bouncing signals 	<ul style="list-style-type: none"> • Check control panel and unit addressing • Check DMX cables • Install terminator as suggested

Contact an authorized service center in case of technical problems or not reported in the table can not be resolved by the procedure given in the table.



WARNING! Before carrying out any operations with the unit, carefully read this instruction manual and keep it with care for future reference. It contains important information about the installation, usage and maintenance of the unit.



SAFETY

General instruction

- The products referred to in this manual conform to the European Community Directives and are therefore marked with **CE**.
- The unit is supplied with hazardous network voltage (230V~). Leave servicing to skilled personnel only. Never make any modifications on the unit not described in this instruction manual, otherwise you will risk an electric shock.
- Connection must be made to a power supply system fitted with efficient earthing (Class I appliance according to standard EN 60598-1). It is, moreover, recommended to protect the supply lines of the units from indirect contact and/or shorting to earth by using appropriately sized residual current devices.
- The connection to the main network of electric distribution must be carried out by a qualified electrical installer. Check that the main frequency and voltage correspond to those for which the unit is designed as given on the electrical data label.
- This unit is not for home use, only professional applications.
- Never use the fixture under the following conditions:
 - in places subject to vibrations or bumps;
 - in places with a temperature of over 40 °C.
- Make certain that no inflammable liquids, water or metal objects enter the fixture.
- Do not dismantle or modify the fixture.
- All work must always be carried out by qualified technical personnel. Contact the nearest sales point for an inspection or contact the manufacturer directly.
- If the unit is to be put out of operation definitively, take it to a local recycling  plant for a disposal which is not harmful to the environment.

Warnings and installation precautions

- If this device will be operated in any way different to the one described in this manual, it may suffer damage and the guarantee becomes void. Furthermore, any other operation may lead to dangers like short circuit, burns, electric shock, etc.
- Before starting any maintenance work or cleaning the projector, cut off power from the main supply.
- Always additionally secure the projector with the safety rope. When carrying out any work, always comply scrupulously with all the regulations (particularly regarding safety) currently in force in the country in which the fixture's being used.
- Install the fixture in a well ventilated place.
- Keep any inflammable material at a safe distance from the fixture.
- Shields, lenses or ultraviolet screens shall be changed if they have become damaged to such an extent that their effectiveness is impaired.
- The lamp (LED) shall be changed if it has become damaged or thermally deformed.
- Never look directly at the light beam. Please note that fast changes in lighting, e. g. flashing light, may trigger epileptic seizures in photosensitive persons or persons with epilepsy.
- Do not touch the product's housing when operating because it may be very hot.

INTRODUCTION

HEXPAR 12 is an LED PAR with 6-in-1 RGBAW+UV LEDs that projects perfectly mixed and finely tunable color.

FEATURES

- 12 x 10W Hex-color RGBAW+UV LED
- Die-cast housing designed for efficient cooling and road-worthy durability
- High-frequency LED modulation for flicker-free video playback
- Four selectable dimming curves
- Gel frame and gel frame holder included
- Power In and Out connections for linking multiple units
- Built-in sound-active and auto (stand-alone) programs
- USB port for optional UFI wi-fi transceiver for wireless DMX control
- Infrared sensor for optional IR6 remote control

SPECIFICATIONS

Light Source:	12 x 10W RGBAW+UV LED
Output:	350 lux @ 5m
Beam Angle:	25°
Field Angle:	45°
Strobe:	0 - 30 Hz
Dimming:	0-100% dimming, 4 selectable dimming curves
PWM Frequency:	1200 Hz
Control modes:	DMX, Auto, Sound-Active, Koala wireless DMX (with optional UFI transceiver), IR (with optional IR6 controller)
DMX Channels:	6 / 11
Menu:	4-digit LED display
Mains:	100 - 240 VAC, 50/60 Hz (auto-ranging)
Power:	83W
Power connections:	IEC power In/Out
Power Linking:	Up to 9 units @ 120V ~ Up to 16 units @ 230V
Data connections:	5-pin XLR In/Out for DMX
Housing:	Die-cast Aluminium
Finish:	Matte Black
IP rating:	IP20
Cooling:	Passive
Dimensions:	253 x 290 x 98 mm
Weight:	3.2 KG

MASTER/SLAVE OPERATION (via UFI wi-fi transceiver)

HEX-PAR 12 units can operate in Master/Slave mode wirelessly using the optional UFI wi-fi transceiver. The master UFI-enabled unit can be operated in stand-alone mode, with the UFI set to transmit. The slave units should all be set to slave mode, with the UFI set to receive.

- Note: Slave units should be configured before configuring master unit
 Note: All units should be set to same DMX address, mode and UFI channel

Setup as below:

SLAVE UNITS:

Press MENU button until **6-CH** or **11-CH** is displayed
 Press ENTER
 Set DMX address to **d 1**
 Set UFI to preferred receiving channel (1-16)
 Attach UFI to the HEX-PAR 12's USB port

MASTER UNIT:

Press MENU button until DMX mode is displayed that matches slave configuration
 Press ENTER
 Set DMX address to **d 1**
 Set to Auto or Sound-Active mode
 Set UFI to chosen transmitting channel (1-16)
 Attach UFI to the HEX-PAR 12's USB port

OPERATING MODE PRIORITY RANK

Higher priority control modes override lower priority modes

1. UFI
2. DMX (wired)
3. Infrared (IR6 remote)
4. Manual (onboard menu)

MASTER/SLAVE OPERATION (via DMX cable)

When multiple HEX-PAR 12 units are used together, Master/Slave mode enables the assignment of one master unit and multiple slave units. The master unit can be operated in stand-alone mode (i.e., auto program or sound-active mode -- not DMX mode). The slave units should all be set to slave mode as described below.

Note: Slave units should be configured and connected before linking to master unit

Setup as below:

SLAVE UNITS:

Press MENU button until **6-CH** or **11-CH** is displayed
 Press ENTER
 Set DMX address to **d 1**
 Connect DMX cable from master unit to DMX In connector
 Link following slave units in similar cable configuration

MASTER UNIT:

Set to Auto or Sound-Active mode
 Link to slave units, beginning from the master DMX Out connector

OVERVIEW

Rear View

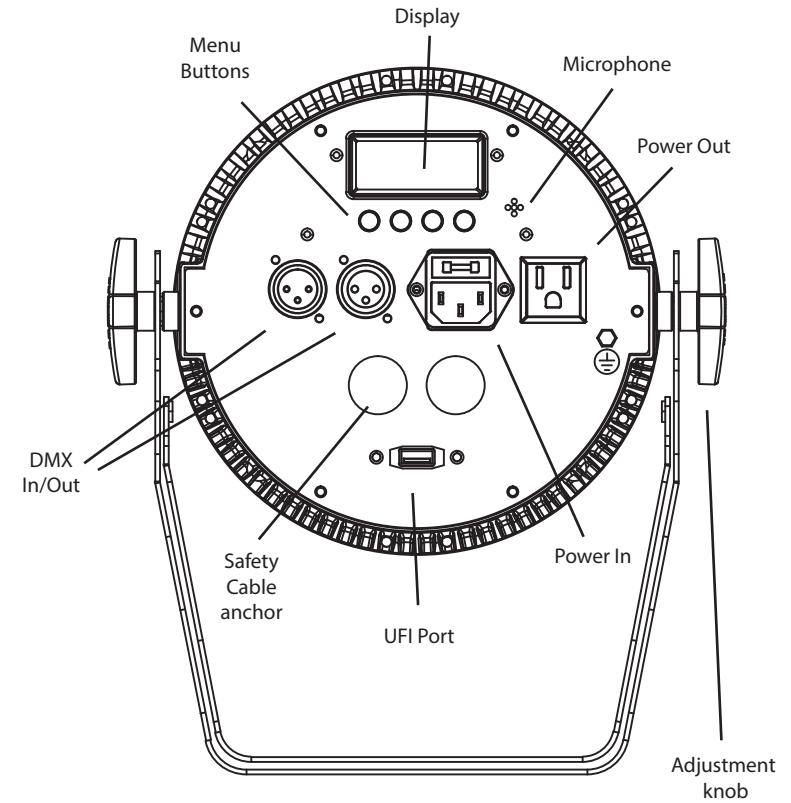

DIMENSIONS

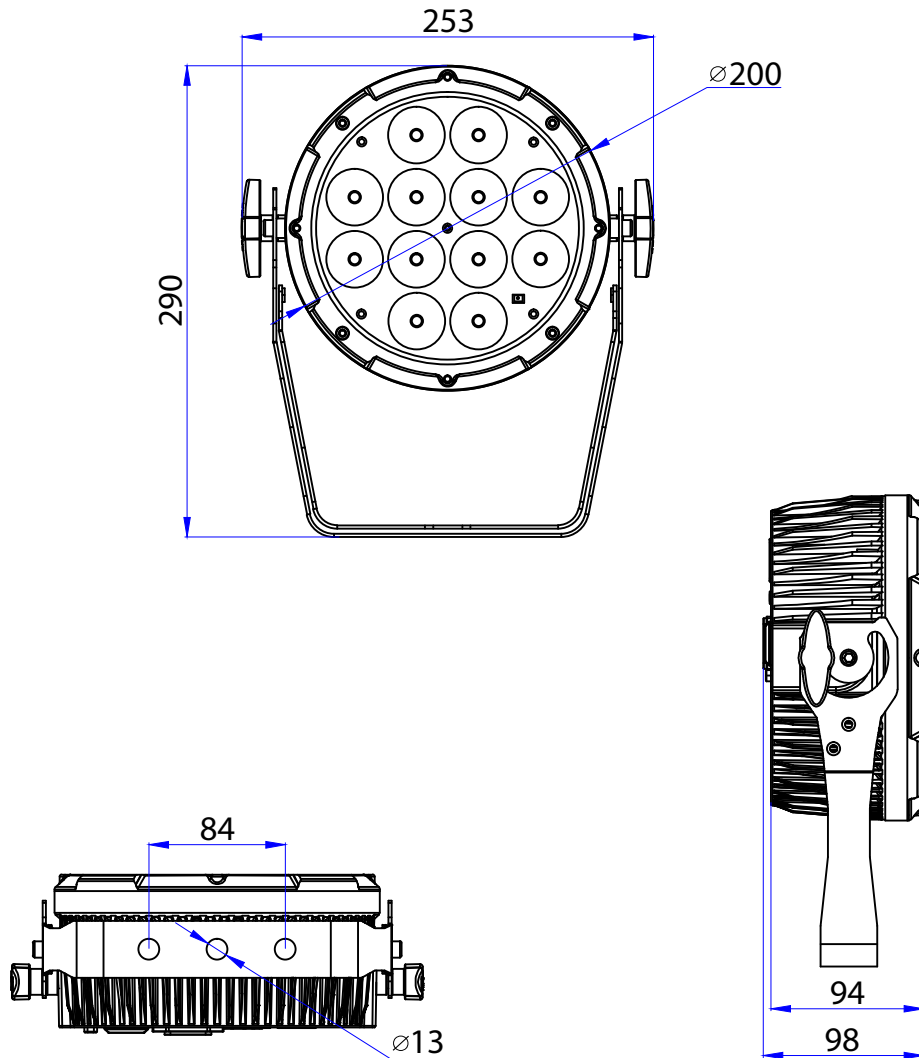

INFRARED (IR6) REMOTE CONTROL OPERATION

The IR6 infrared controller enables remote control of the HEX-PAR 12.

To pair the IR6 to the HEX-PAR 12, follow these steps:

1. Press MENU button until **SEr** is displayed
2. Press ENTER
3. Press UP or DOWN to turn infrared operation ON or OFF
4. Press ENTER

IR6 BUTTON FUNCTIONS

AUTO	: Run auto programs
FADE	: Fade auto programs
SPEED	: Enable speed adjustment of auto programs
+ / -	: Increase / decrease speed of auto programs
SOUND	: Activate sound-active mode
SENSITIVITY	: Enable sound sensitivity adjustment
+ / -	: Increase / decrease sound sensitivity
MANUAL	: Enable static color selection
0-9	: Select static colors
R	: Select red
G	: Select green
B	: Select blue
A	: Select amber
W	: Select white
UV	: Select UV
+ / -	: Increase / decrease output of each color
%	: Enable adjustment of total light output level
+ / -	: Increase / decrease total light output
STROBE	: Enable adjustment of strobe rate
+ / -	: Increase / decrease strobe rate
STROBE	: Press again to turn off strobe
BLACKOUT	: Turn off all light output
BLACKOUT	: Press again to exit blackout mode
Note:	: If IR6 remote is not responding, press BLACKOUT to confirm that blackout mode was not mistakenly activated

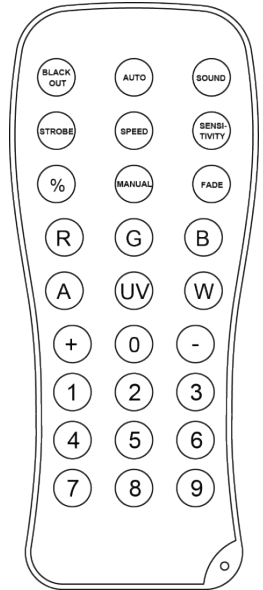

STAND-ALONE OPERATION

PRESET COLOR MODE

Press MENU button until **C--** is displayed
 Press ENTER
 Press UP or DOWN to select **C1 - C63**
 Press ENTER

AUTO PROGRAM MODE

Press MENU button until **P--** is displayed
 Press ENTER
 Press UP or DOWN to select **P1 - P4**
 Press ENTER

SELECTING PROGRAM SPEED

Press MENU button until **S--** is displayed
 Press ENTER
 Press UP or DOWN to select speed
 Press ENTER

SOUND-ACTIVE MODE

Press MENU button until **Snd** is displayed
 Press ENTER
 Press UP or DOWN to select **Snd1** or **Snd2**
 Press ENTER

ADJUSTING SOUND SENSIVITY

Press MENU button until **Sens** is displayed
 Press ENTER
 Press UP or DOWN to adjust mic sensitivity
 Press ENTER

COLOR MIXING MODE

Press MENU button until **U--** is displayed
 Press ENTER to scroll to each color setting for amber, cool white, and warm white
 Press UP or DOWN to adjust output (**r---**, **g---**, **b---**, **A---**, **W---**, **P---**)

SELECTING DIMMER CURVES

Press MENU button until **dIM** is displayed
 Press ENTER
 Press UP or DOWN to select dimmer curve (**OFF**, **dIM1**, **dIM2**, **dIM3**)
 Press ENTER

ACTIVATING INFRARED REMOTE MODE

Press MENU button until **SEr** is displayed
 Press ENTER
 Press UP or DOWN to select **On** or **OFF**
 Press ENTER

CONTROL MENU OVERVIEW

CONTROL PANEL

BUTTON	FUNCTION
Menu	Selects operating mode or exits submenus
Up	Scrolls up through option lists or selects higher value
Down	Scrolls down through option lists or selects lower value
Enter	Activates displayed menu option or selected value

FUNCTION MENU

MODE	OPTIONS / VALUES	DESCRIPTION
6-CH	d001-512	6-channel DMX mode
11-CH	d001-512	11-channel DMX mode
C--	C1-63	Static color selection
P-- (automatic)	P1	Auto Program 1
	P2	Auto Program 2
	P3	Auto Program 3
	P4	Auto Program 4
S--	S--1-100	Program speed for P1-P4
Snd (sound-active)	Snd1	Sound-active Program 1
	Snd2	Sound-active Program 2
Sens	u-0-100	Sound sensitivity
U--	R000-255 (Red)	Custom static colors Mix red, green, blue, amber, white and UV
	G000-255 (Green)	
	B000-255 (Blue)	
	A000-255 (Amber)	
	W000-255 (White)	
	P000-255 (UV)	
dIM	OFF	Dimmer speed settings
	dIM1	
	dIM2	
	dIM3	
SEr	On	Turns infrared on or off
	OFF	

UFI OPERATION

To enable wireless DMX operation via the optional UFI wi-fi transceiver:

- 1) Set the HEX-PAR 12 starting DMX address
- 2) Set the UFI sending/receiving channel
- 3) Attach the UFI to the HEX-PAR 12 USB port
- 4) Use Dipswitch 5 to select UFI send or receive mode.



DMX FUNCTION CHART

11-Channel Mode

Channel	Function	Value	Percent/Setting
1	Red	000 --- 255	0-100%
2	Green	000 --- 255	0-100%
3	Blue	000 --- 255	0-100%
4	Amber	000 --- 255	0-100%
5	White	000 --- 255	0-100%
6	UV	000 --- 255	0-100%
7	Color Macros (Overrides Ch. 1 -6)	000 --- 015	No function
		016 --- 255	Color macros
8	Strobe (when CH 9 is 000-031)	000 --- 015	No function
		016 --- 255	Slow to fast
	Speed (when CH 9 is 032-223)	000 --- 255	Slow to fast
	Sound Sensitivity (when CH 9 is 224-255)	000 --- 010	Off
		011 --- 255	Controls the sound sensitivity level
9	Mode	000 --- 031	No function
		032 --- 063	Pulse effect 0 -100%
		064 --- 095	Pulse effect 100% -0%
		096 --- 127	Pulse effect 100% -0-100%
		128 --- 159	Auto fade transition
		160 --- 191	Auto snap transition (6 colors)
		192 --- 223	Auto snap transition (63 colors)
224 --- 255	Sound -active mode		
10	Dimmer	000 --- 255	0-100%
11	Dimmer Speed	000 --- 051	Default dimmer speed set from menu
		052 --- 101	Dimmer speed mode off
		102 --- 152	Dimmer speed mode 1 (fast speed)
		153 --- 203	Dimmer speed mode 2 (medium speed)
		204 --- 255	Dimmer speed mode 3 (slow speed)

CH1~ 6 must be active

6-Channel Mode

1	Red	000 --- 255	0-100%
2	Green	000 --- 255	0-100%
3	Blue	000 --- 255	0-100%
4	Amber	000 --- 255	0-100%
5	White	000 --- 255	0-100%
6	UV	000 --- 255	0-100%